

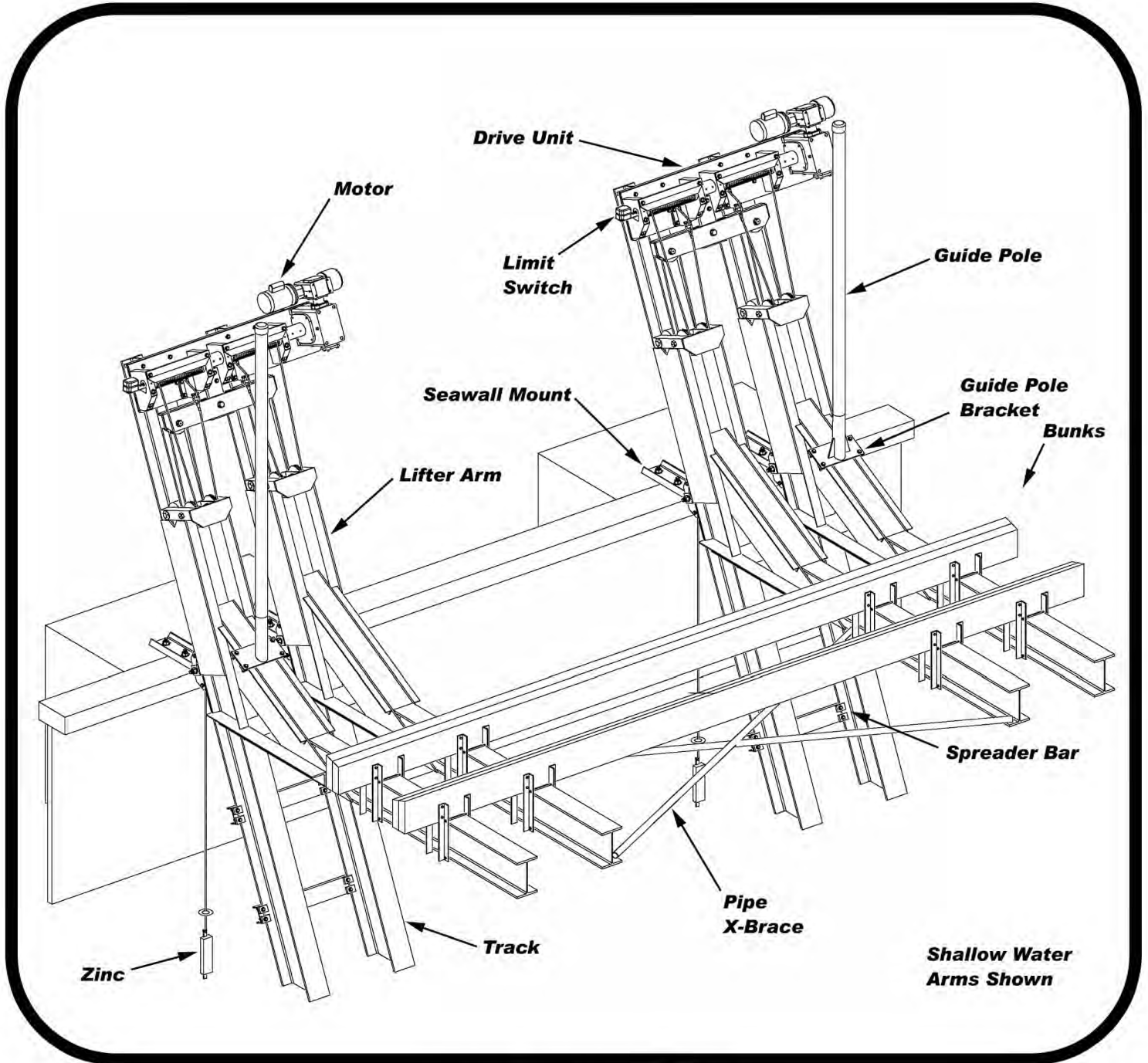

ALUMINUM ELEVATOR

50,000 Lb. Installation Manual

Revised 12-1-2025



www.hi-tide.com

4050 Selvitz Road • Fort Pierce, Florida 34981
(772) 461-4660 • 1-800-544-0735 • Fax (772) 577-6934

INTRODUCTION

At Hi-Tide Sales, we take pride in bringing the most advanced, easy to use, minimum maintenance boat lift system to the market today. The installation of this lift is simplified by its lightweight design and simple operation. In the pages that follow, we will take you step-by-step through the entire installation sequence, including the lifting of the boat. We urge you to read this manual completely before attempting an installation.

Before you begin...

Lift installation must adhere to Local and/or National Building Codes. The Aluminum Elevator must be mounted to a solid concrete counterweight base. The concrete is the foundation of the boat lift and must be able to carry the load of the lift and the boat to be lifted. The installer is responsible to verify the structural integrity of any existing concrete and/or the proper installation of any new concrete to ensure a secure attachment and counterweight support. Consult Hi-Tide with any installation questions.

Step 1: Attaching Mounts

Typical Install of Concrete Seawall Mount - Install 3/4" dia. concrete anchors (not supplied) into seawall cap. Pour concrete for counterweight in hole behind cap with 3/4" dia. J-Bolts (not supplied) installed in the concrete. DO NOT LOAD LIFT FOR TWO DAYS AFTER COMPLETION.

**MINIMUM REQUIRED
CONCRETE COUNTERWEIGHT**

50,000 lbs.....7 yards per Track

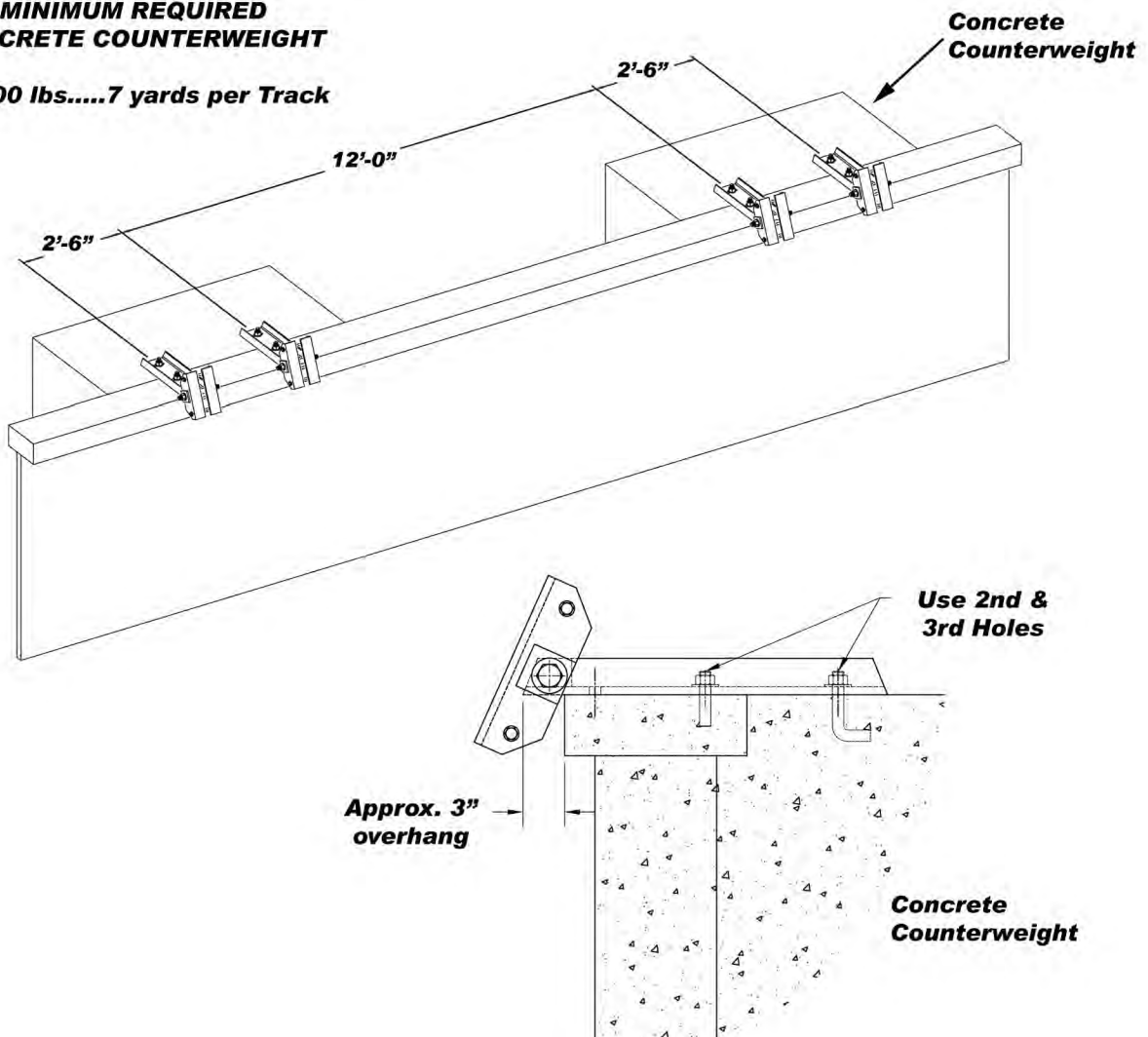

Step 2: Install Tracks and Lifters

Using the 24 degree reference mark on the mount and using the supplied Angle Finder, hammer tracks into ground to refusal. It is up to the installing contractor to determine if the tracks are installed correctly and securely. Seawall Mounts will allow for up to 2" of side-to-side adjustment. Be certain tracks are parallel top to bottom and plum with a centered bubble on a carpenter's level, then tighten all bolts.

1) Hammer tracks at 24 degrees into ground to refusal. Cut all tracks to uniform height (if necessary).

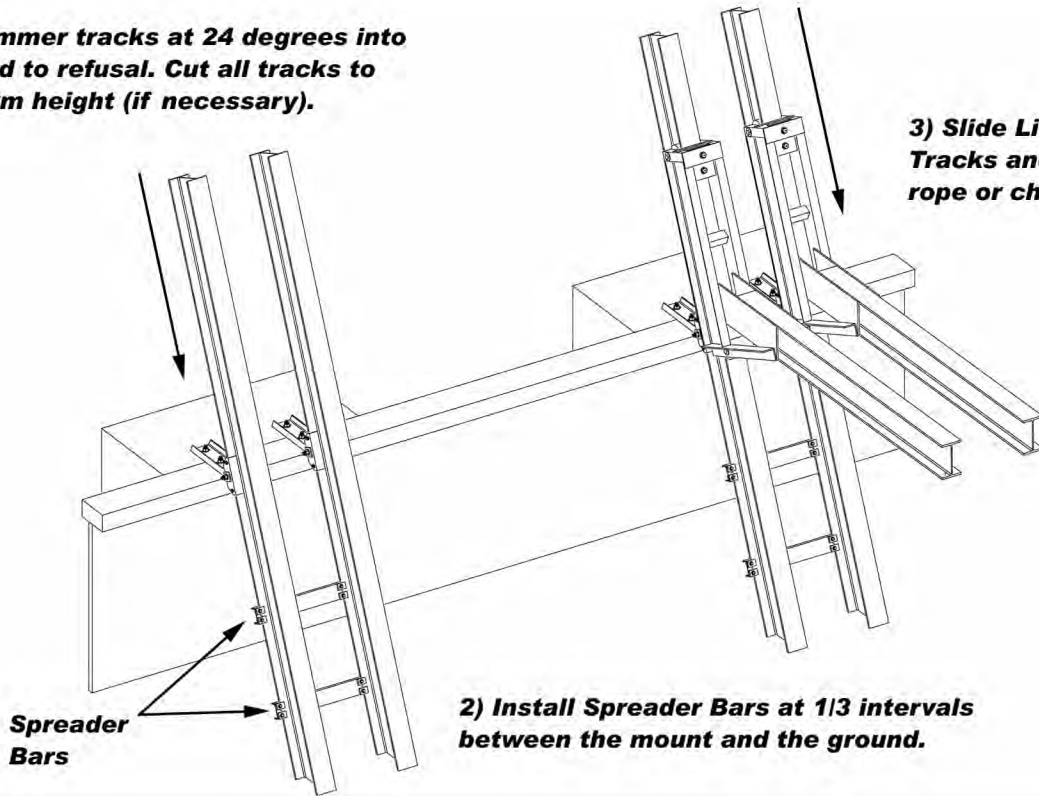

2) Install Spreader Bars at 1/3 intervals between the mount and the ground.

Step 3: Install Drive Units and Motors

1) Slide Drive Unit over Track ends into back clamps. Confirm Drive Units are centered with the tracks and level with a centered bubble on a carpenter's level. Adjust clamps against tracks and tighten all hardware.

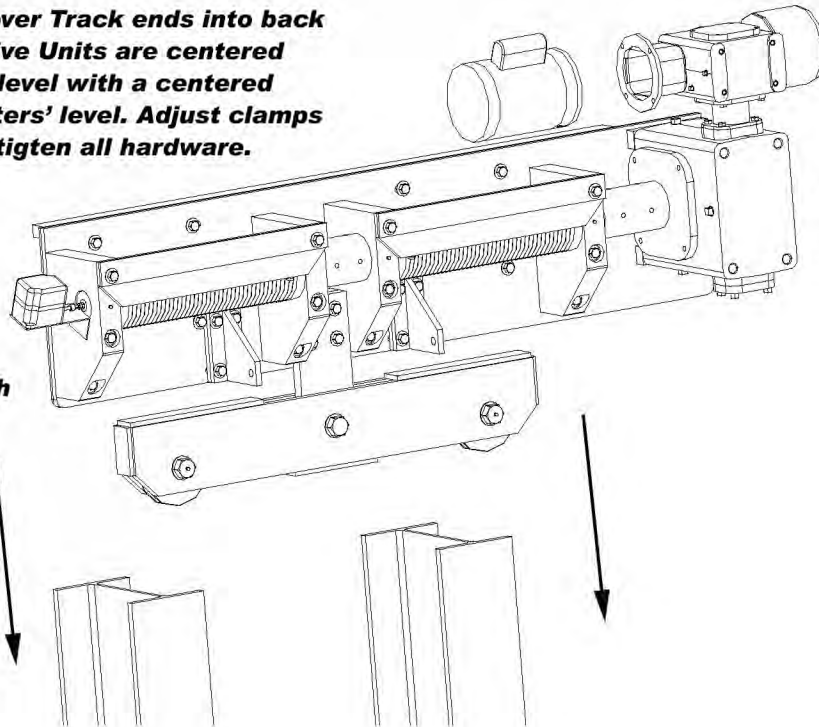

2) Attach Motor to Gearbox & install Canvas Cover over Motor.

3) Attach Limit Switch to Drive Unit.

Step 4: Wiring the Lift

Boat Lift Electrical Requirements:

Having the proper electrical service to your boat lift is critical to the satisfactory operation of the lift. As a minimum, the following 75C copper conductor wire sizes must be observed to preclude possible voltage drop and damage to electrical components. Follow wiring instructions affixed to Motors, Remote Control and GFCI breaker. Hi-Tide has provided a Complete Disconnect Switch that must be installed to prolong the life of the tracks and minimize damage from electrolysis or stray current present in the water.

Motor H.P.	100 Feet	200 Feet	300 Feet	400 Feet
	240V	240V	240V	240V
(2) 2 HP	#10	#8	#6	#4

Important Notes:

- When at all possible, electrical services should be dedicated to the boat lift only to avoid interference by other electrical appliances. **DO NOT USE EXTENSION CORDS.**
- Please do not change or ignore wiring diagrams, or instructions as shown. There may be other ways to make it work, but our way is the only way approved by us (the Manufacturer)
- The wiring suggestions and wiring diagrams referred to are not meant to supersede any national or local codes. Electrical work is recommended to be performed by a licensed electrical contractor.

Step 5: Routing Cables

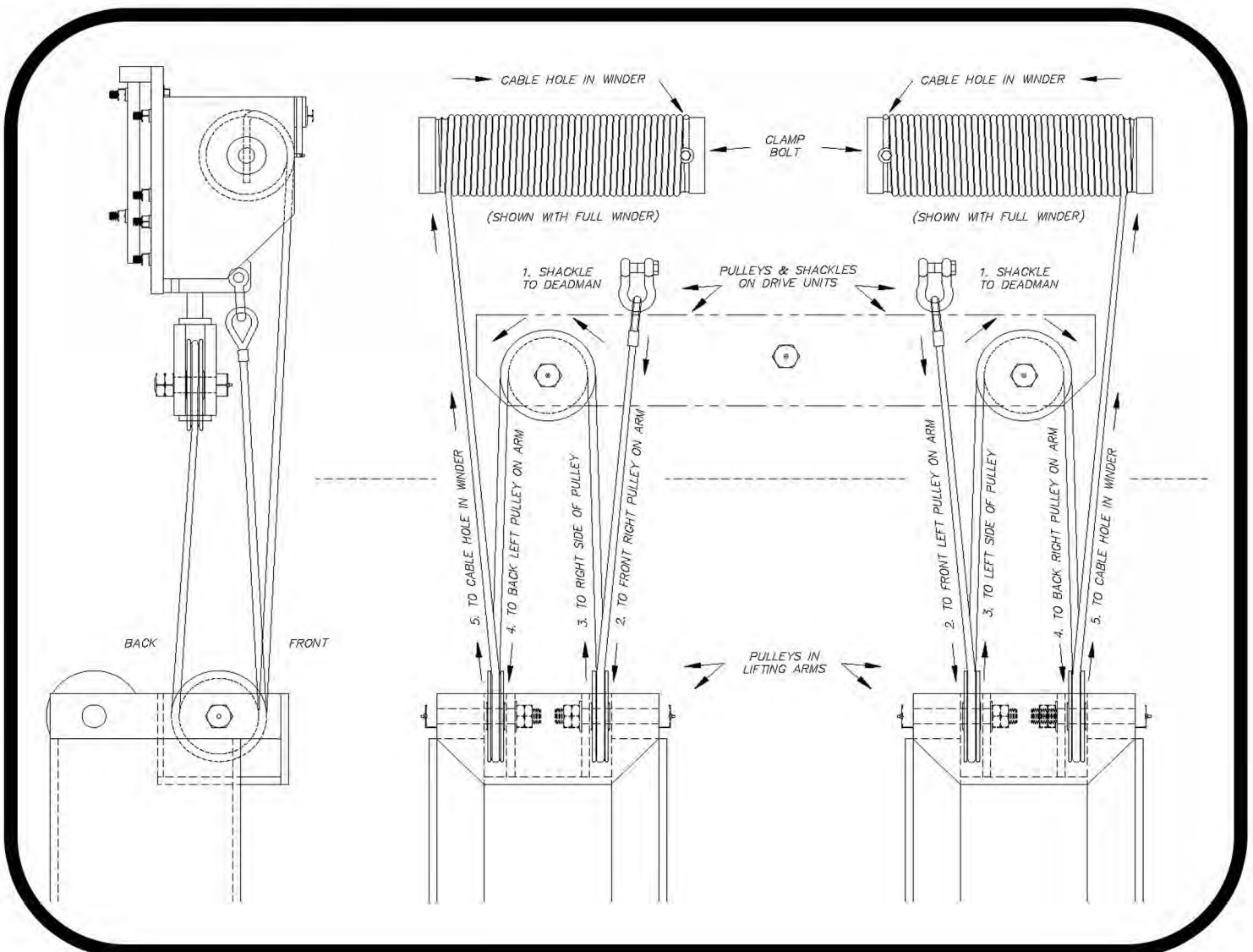

Step 6: Constructing the Lift Cradle

Wind cables to raise arms above water and allow lifter arms to hang freely and level with each other. Double check with level to insure proper installation of bunks. Bunks should be centered on Lifter Arms, bow to stern. Contact Hi-Tide as necessary if custom bunking is to be used.

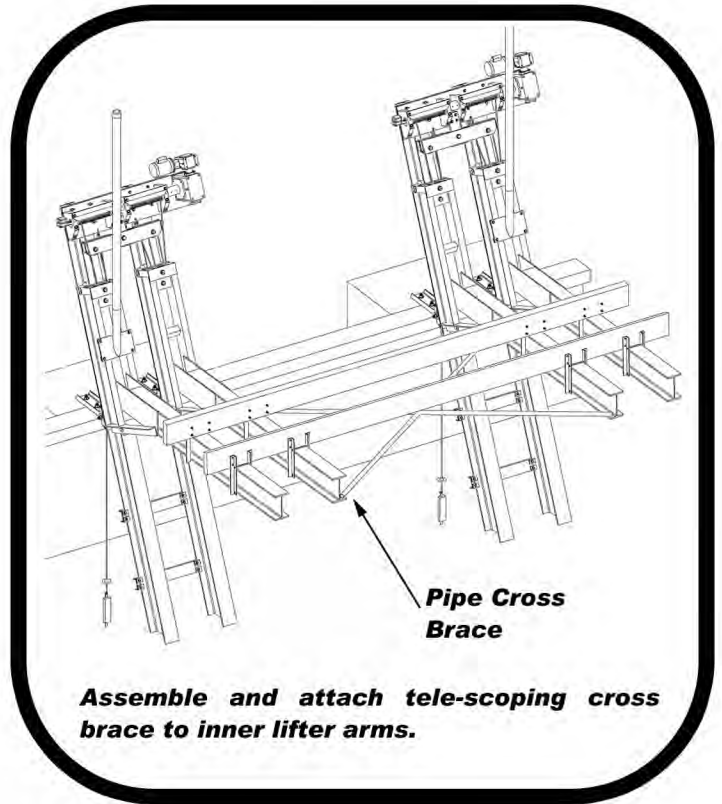
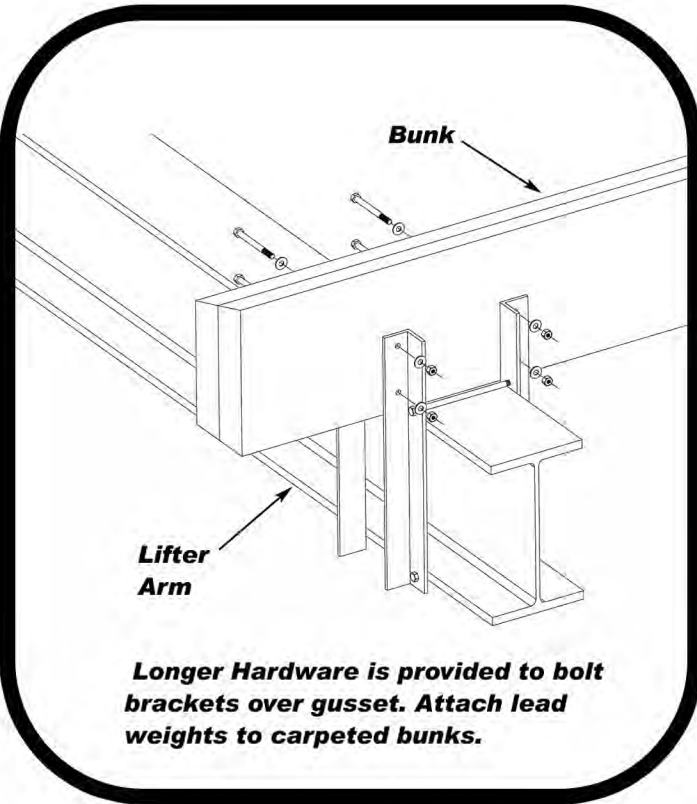

Step 7: Completing the Installation

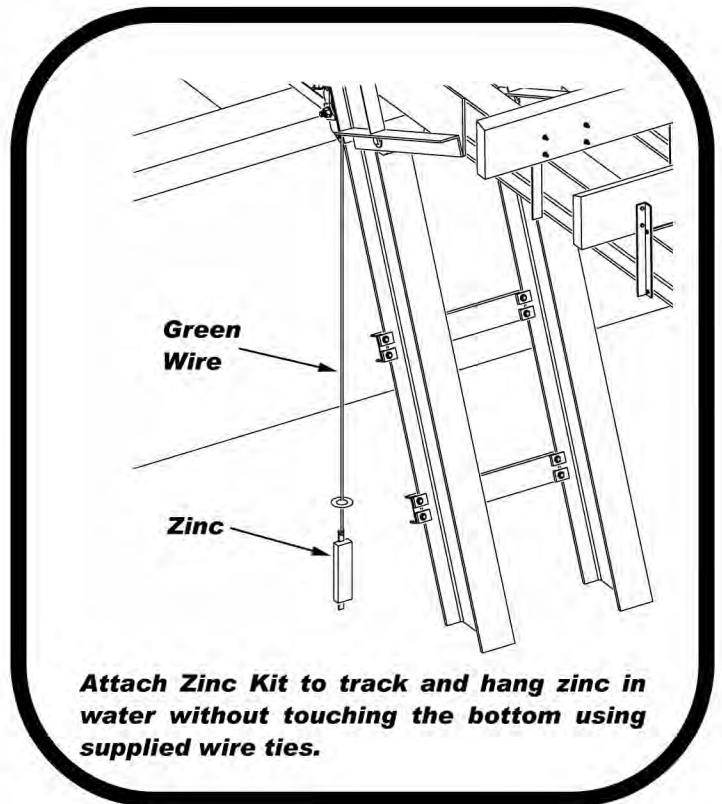
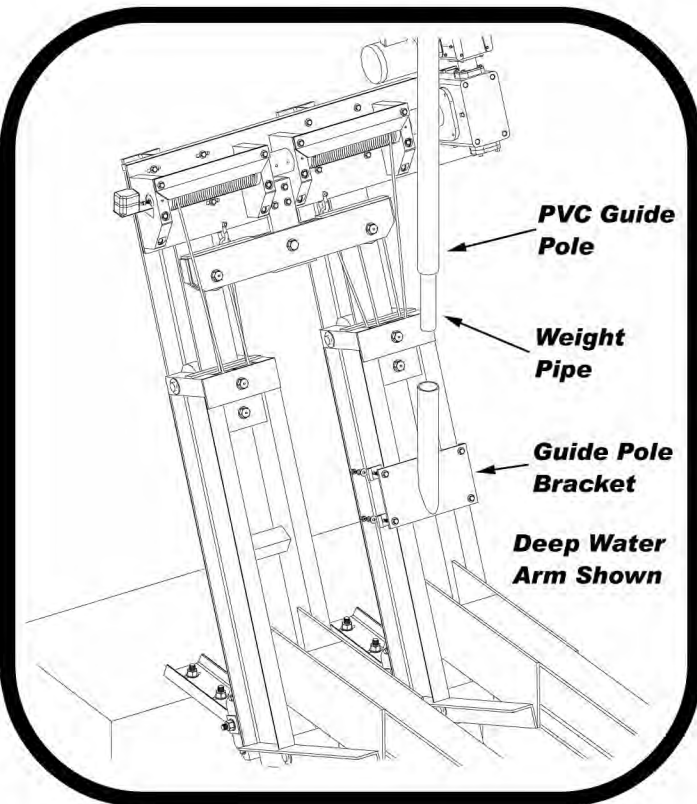

Boat Fitment

Take care to clear shafts, thru-hull fittings, chines, skegs, etc. Keel of vessel must not rest on lifter arms and should clear arm by at least one inch. Center of gravity of boat must be in center of lift (bow to stern). This will evenly distribute the load over the lifter arms. The vessel keel center must not cross the CENTERLINE sticker that is applied on top of the lifter arms.

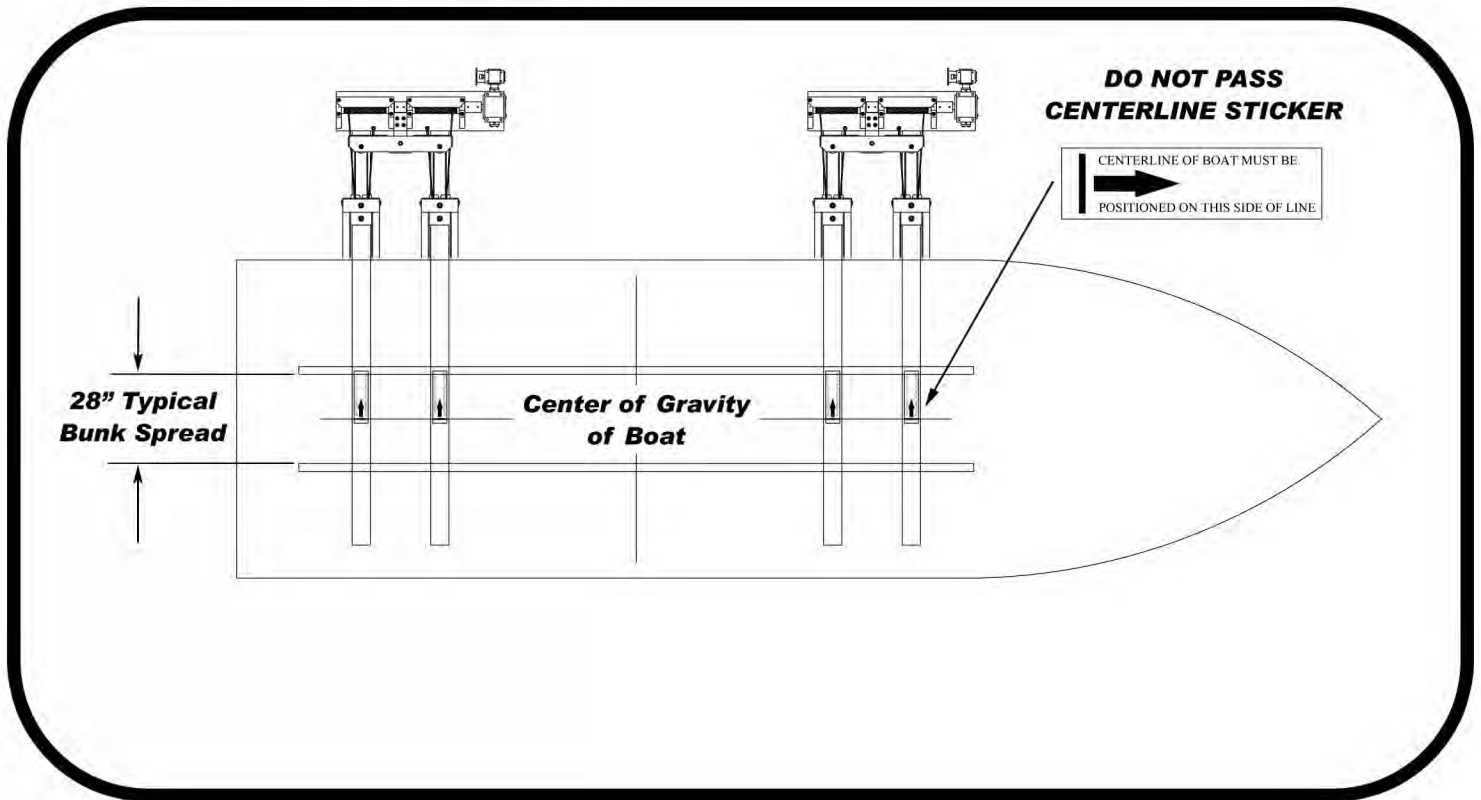

Helpful Hints:

- A reference mark can be placed on a guide pole to indicate that the cradle is deep enough for the boat's hull to clear the cradle. This will assure clearance entering and leaving the cradle as the tide changes.
- For shallow water installations, a reference mark can be placed on a cable to indicate that the cradle has almost contacted bottom. Turning lift off at this point will prevent the cable winds from slacking and becoming tangled. If shallow water conditions exist, Hi-Tide strongly recommends the fitment of a limit switch.

Important Notes to Installer:

It is the responsibility of the installer to insure that:

- 1) The installation is completed according to the manufacturer's recommendations.
- 2) The ultimate user understands how to operate in a safe manner.
- 3) The ultimate user acknowledges the need for regular service and maintenance of the lifting equipment by an authorized Hi-Tide dealer.
- 4) The customer is informed and understands all safety and warning labels affixed to the equipment.
- 5) The center of gravity of boat is confirmed by equal tension on the lifting cables.

No Alterations or modifications may be made to the Hi-Tide equipment without expressed written consent of Hi-Tide Sales, Inc. Re-installation of the Hi-Tide equipment must be performed by an authorized Hi-Tide Agent/Dealer and must be performed to the standards set forth by Hi-Tide Sales, Inc. Transfer of any remaining warranty to a new location is solely at the discretion of Hi-Tide Sales, Inc. It is the obligation of the re-installer to inform any new operators of the above conditions. Maintenance/Owners Manuals and safety decals are available on request from Hi-Tide Sales, Inc.